

# PLACIS Days 2015

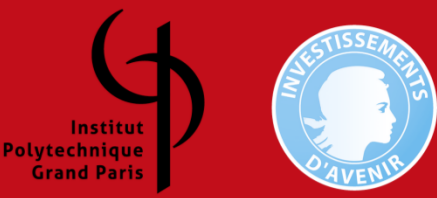

## System Approach to the Pre-Design of a Test Bench for Electric Vehicles Engineering

### Project Context

The aim of this project is to reduce the costs related to physical experiments performed on real electric vehicle test benches, by designing a useful engineering tool that could computationally simulate that situation and provide solutions to the most common problems encountered on the domain of battery-powered vehicles.

### RFLP Approach

The methodology used for the development of the virtual test bench was based on the Logical and Physical levels of the RFLP Approach. To achieve this objective, the two following engineering softwares were used:



While Dymola® performs the simulations, ModelCenter® is responsible for evaluating and optimizing the parameters of the test bench model.

### Dymola Model

Using the Modelica® Libraries and specifying the equations with its open modeling language, the idea of the Dymola Model was to create a virtual electric vehicle based on the test bench of *Istituto Motori* (IM).

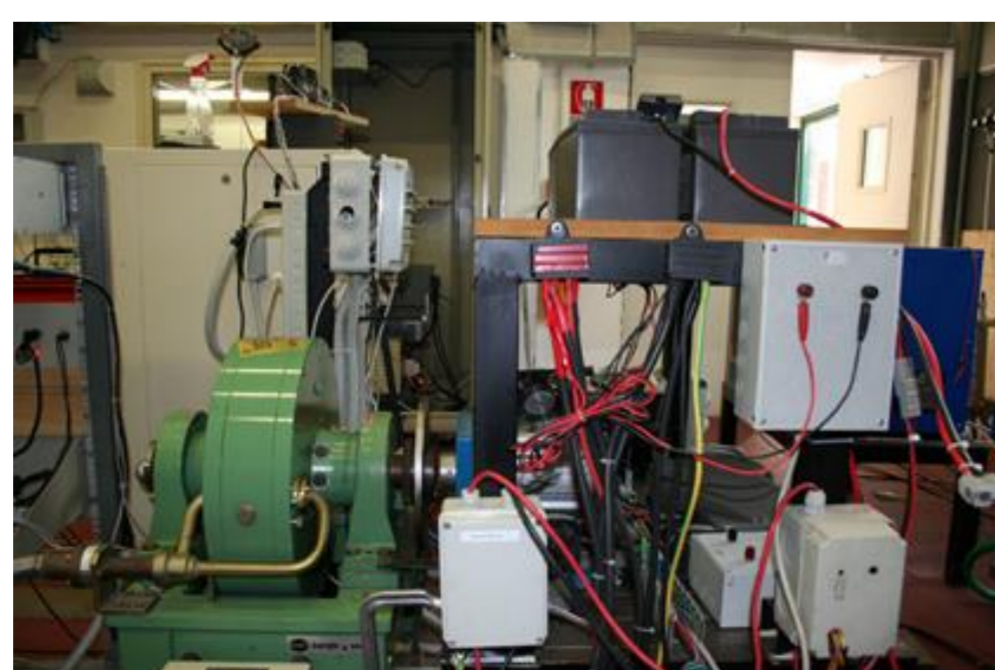

Basically, it's composed of a battery pack, an inverter, an electric synchronous motor, a control system, a transmission system, blocks of resistive forces and tables of reference data.

In order to validate the model, the same study case considered by IM was taken into account when determining the values of the parameters of the Dymola test bench. So, the performed analysis was based on the characteristics of a motorcycle Scooter.

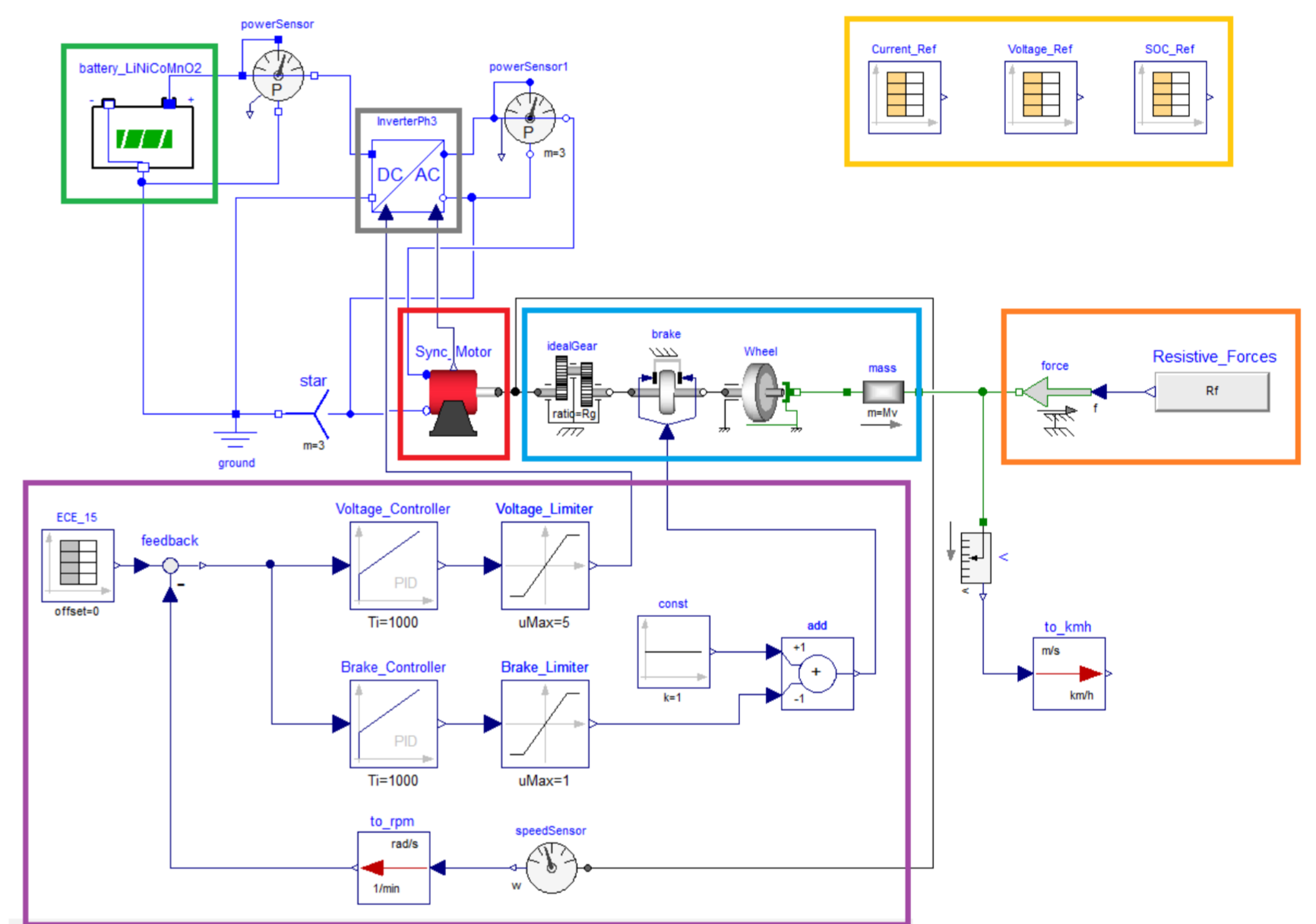

### Results

The comparison between the Dymola Model results and the experimental results collected by *Istituto Motori* on the Scooter Test Bench shows a similar behavior of the graphics of battery current and voltage, although the relative error tend to increase in some points.

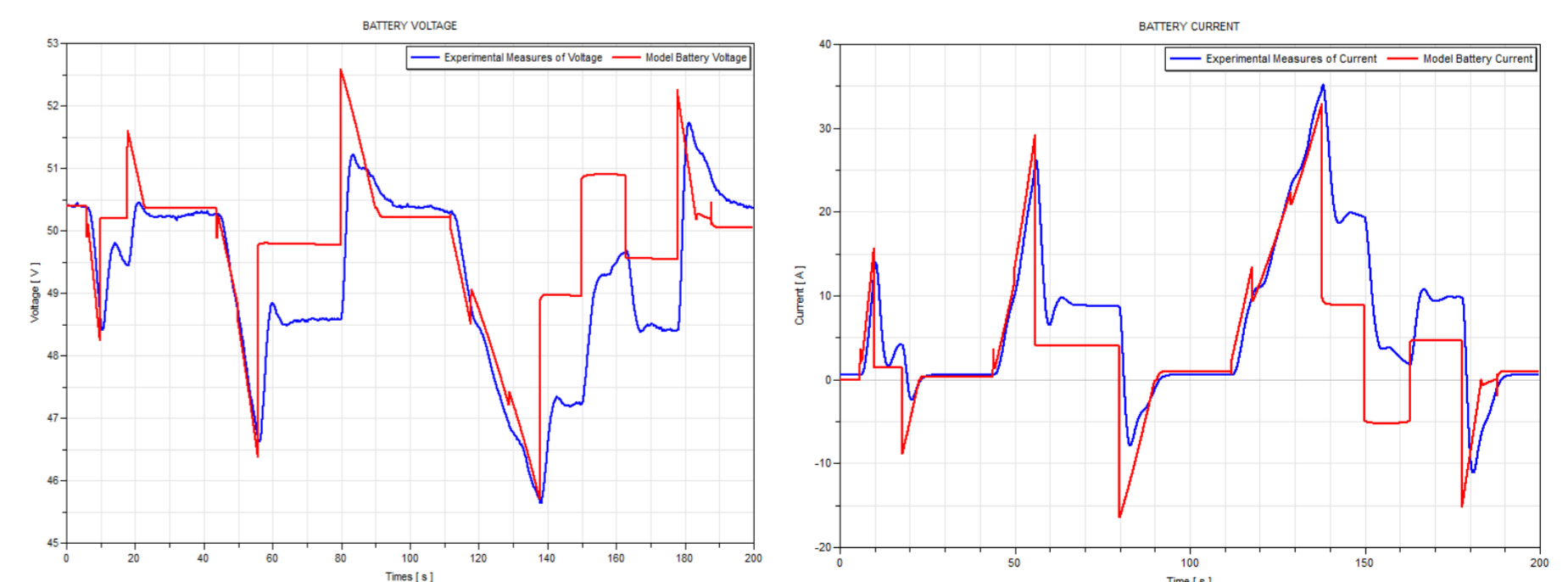

IEBBA  
Maurizio

CAMARGO ROSA  
Felipe

Pr. Tutors:

HAMMADI  
Moncef

VENERI  
Ottorino

PATALANO  
Stanislao

BRUNNER  
Antoine

